

bornes de recharge Green'up

Principe d'installation d'une borne individuelle mixte Mode 2 / Mode 3

Monophasé

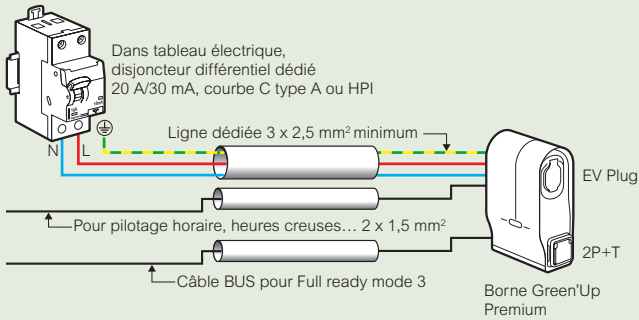

Triphasé

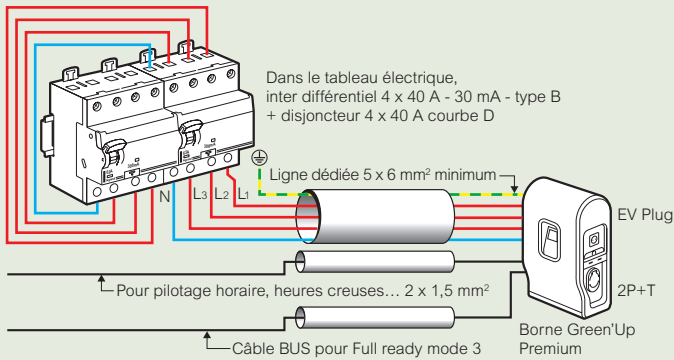

Attention : prévoir 2 lignes pour une borne de recharge pour 2 véhicules (2 x EV Plug et 2 x 2P+T)

Principe d'installation de plusieurs bornes mixtes mode 2 / mode 3

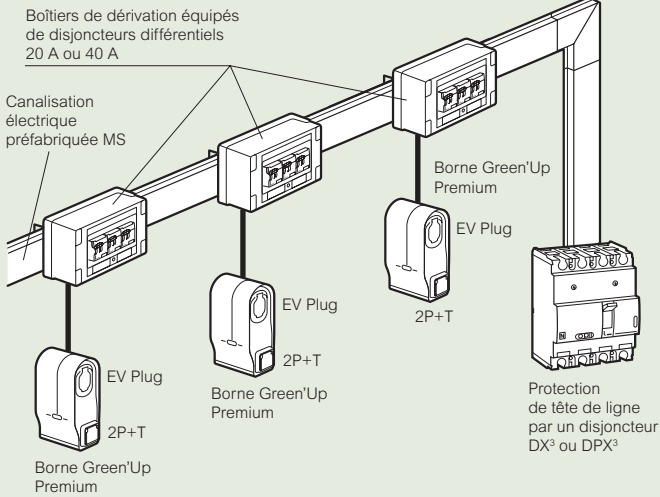

Dimensions

Bornes fixation murale

Réf. 0 590 73//75/76

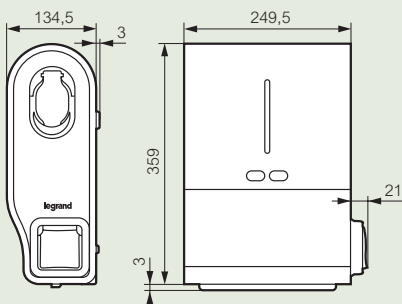

Bornes sur pied

Réf. 0 590 74

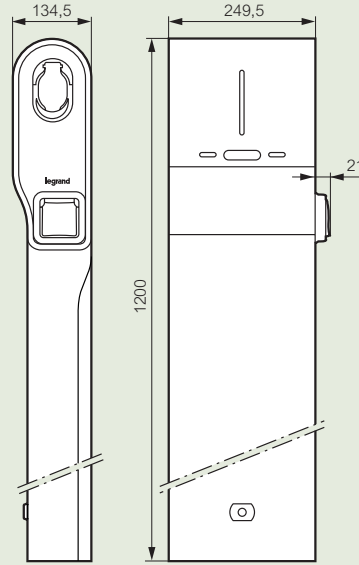

Bornes fixation murale

Réf. 0 590 57/61/64/66/77/91/94/96

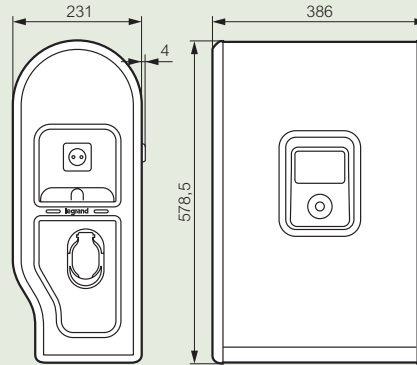

Bornes sur pied

Réf. 0 590 58/63/65/67/78/93/95/97

