

# EMS CX<sup>3</sup> - Mini-configurator & on-site display

Cat. N°: 4 149 36/37



Contents	Pages
1. Description - Use .....	1
2. Range .....	1
3. Overall dimensions .....	1
4. Preparation - Connection .....	1
5. General characteristics .....	4
6. System architectures .....	8
6.1 Stand Alone .....	8
6.1.1 with local addressing .....	8
6.1.2 with remote addressing .....	9
6.2 Supervised .....	10
6.2.1 with local addressing .....	10
6.2.2 with remote addressing .....	12
7. Compliance and approvals .....	14

## 1. DESCRIPTION - USE

- . Module dedicated to Energy Management System (EMS CX<sup>3</sup>) use.
- . On site, in stand-alone (without any computer or IP) allows to display data (measure, status, command and alarms) and to make several configurations of EMS CX<sup>3</sup> devices.

## 2. RANGE

- . Cat. n° 4 149 36: Mini configurator display with English, French, Italian, Flemish, Polish, Spanish, German, Portuguese and Turkish languages.
- . Cat. n° 4 149 37: Mini configurator display with English, Arabic, Chinese, Greek, and Russian languages.

### Width:

- . 4 modules. 71,2 mm width.

## 3. OVERALL DIMENSIONS

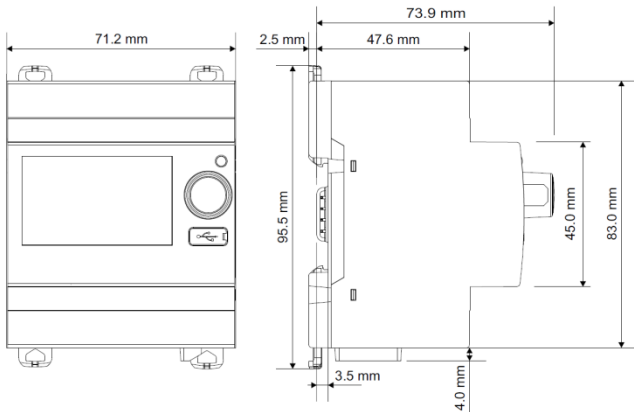

## 4. PREPARATION - CONNECTION

### Fixing:

- . On symmetric rail EN/IEC 60715 or DIN 35 rail

### Operating positions:

- . Vertical, Horizontal, Upside down, On the side

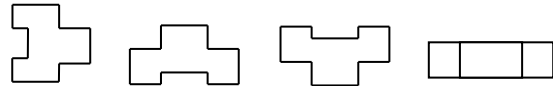

### Power Supply:

- . Mandatory in 12 VDC via the specific Power supply module Cat n°4 149 45
- . Two ways:
  - via specific communication patch cords (cat. nos 4 149 07/08/09) to connect at the downstream through dedicated ports

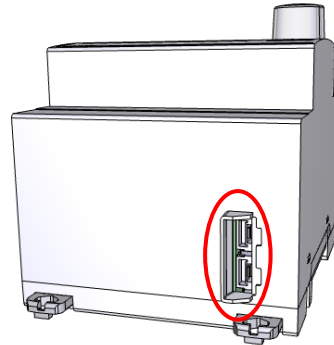

- via specific communication rails (cat. nos 4 149 01/02/03) to connect at the rear through dedicated connectors

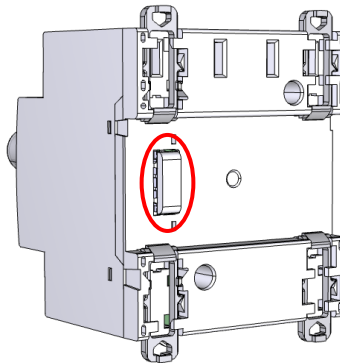

## 4. PREPARATION - CONNECTION *(continued)*

### Recommended tools:

. For fixing: flat screwdriver 5.5 mm (6 mm maximum).

### Data connection (EMS CX<sup>3</sup> modules inter-connection):

. Via specific communication patch cords (cat. nos 4 149 07/08/09)



Allow data transmission between the different EMS CX<sup>3</sup> modules. This type of connection is recommended when there are few EMS CX<sup>3</sup> modules, distributed all over the enclosure.

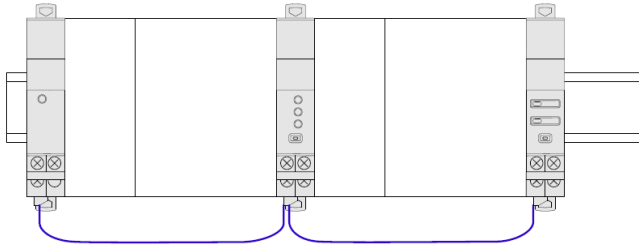

**Implementing:** with this configuration, the plastic protection cover of the backside communication ports on the EMS CX<sup>3</sup> module must be kept on.

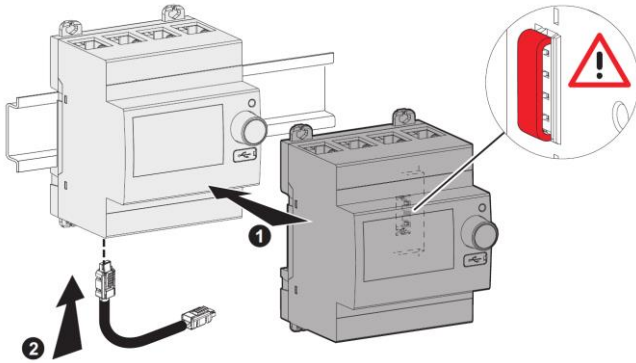

## 4. PREPARATION - CONNECTION *(continued)*

### Data connection (EMS CX<sup>3</sup> modules inter-connection)

*(continued):*

. Via specific communication rails (cat. nos 4 149 01/02/03).

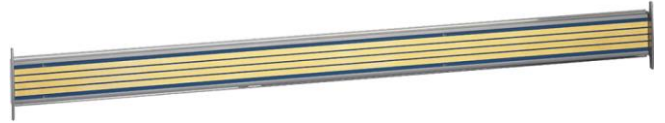

. Allow data transmission between the different EMS CX<sup>3</sup> modules. This type of connection is recommended when there are several EMS CX<sup>3</sup> modules on the same DIN row.

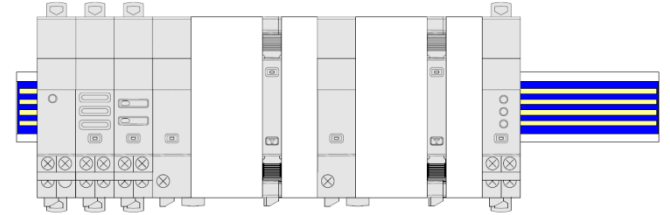

**Implementing:** with this configuration, the plastic protection cover of the backside communication ports on the EMS CX<sup>3</sup> module must be removed.

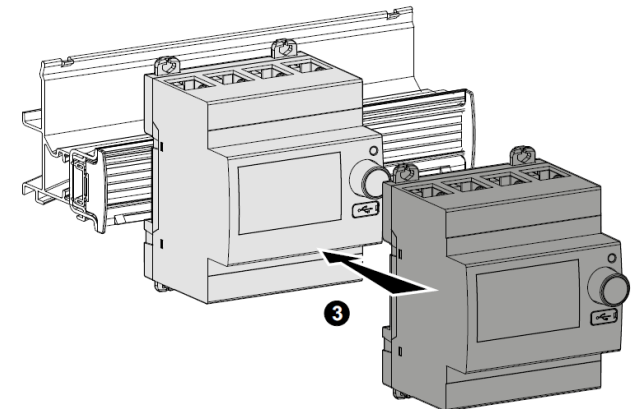
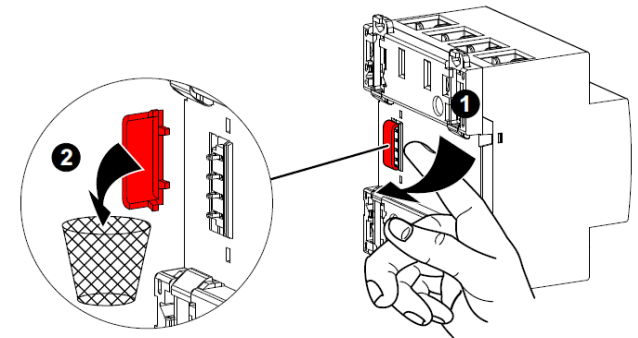

## 4. PREPARATION - CONNECTION *(continued)*

### Data connection (EMS CX<sup>3</sup> modules inter-connection)

*(continued):*

. Via a mix between specific communication patch cords and communication rails in order to create a link between several rows

Two situations:

- Individually connected with communication rails.  
The communication patch cord allows to connect two rows.



- Individually connected with communication patch cords & communication rail.  
The communication patch cords allow to connect EMS CX<sup>3</sup> module on a row and to connect two rows.

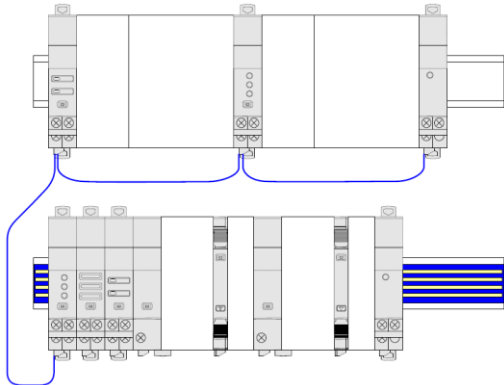

### Front USB port:

. Allows, if needed (e.g. for configuration), to connect the EMS CX<sup>3</sup> Mini-configurator to a computer via a "type B" micro USB/USB commercial cable.

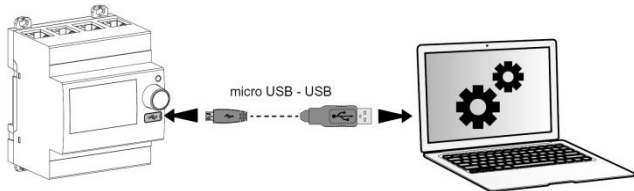

. via the Legrand - EMS configurator software (download for free) is possible to:

- test an EMS installation
- update the module's firmware
- create a link between two modules with Link Functionality
- configure the modules characteristics if the lateral DIP Switches remain on 0000 position (for the modules 4 149 30/32)
- make the extended addressing procedure (see § 6.2.2)

## 4. PREPARATION - CONNECTION *(continued)*

### Position in a row:

. The product profile and the position of the terminals at the downstream allow the insertion of the prong-busbar by the upstream. In this way the position of the EMS CX<sup>3</sup> device in a row can be freely chosen

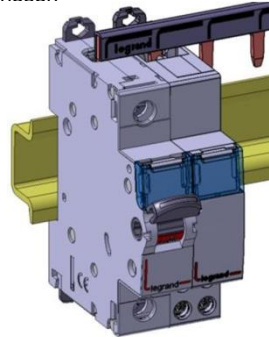

### Module maintenance:

. A device may be replaced in the middle of a row supplied with prong-busbar without disconnecting the other devices.

1. Put the clamp in the unlocking position

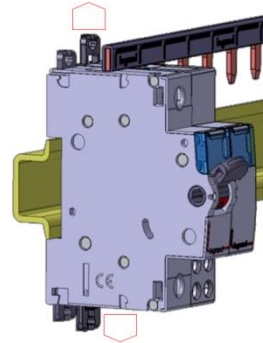

1. Put the clamp in the unlocking position

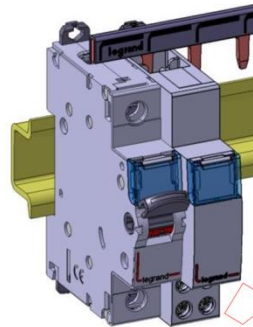

2. Pull the device forward in order to release it from the rail

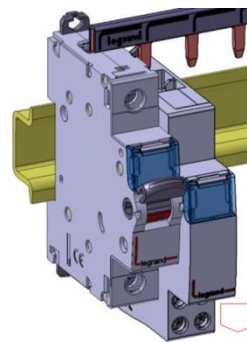

3. Pull the device downward in order to release it completely from the prongs of the busbar

## 5. GENERAL CHARACTERISTICS

### Front face marking:

. By permanent ink pad printing (red line) and laser marking

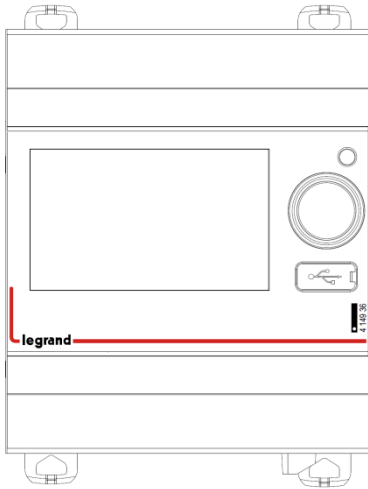

### Lateral side marking:

. By laser.

right side: Standard g and traceability information

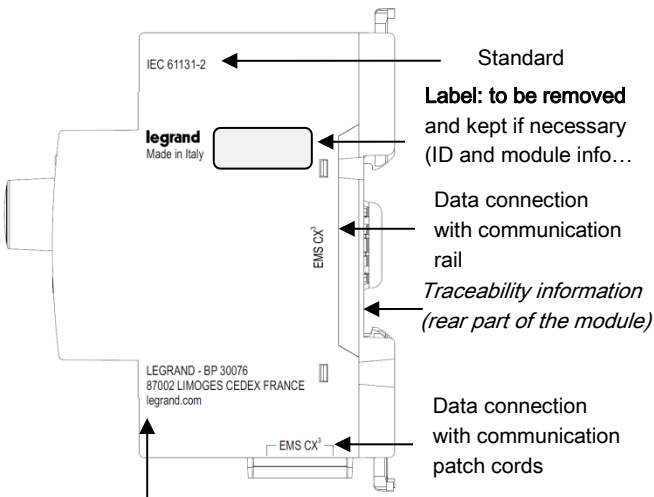

Legrand address

### Rotary button:

. Equipped with a rotary button to browse the mini-configurator pages and to make several configurations:

- Turn: to browse / scroll pages

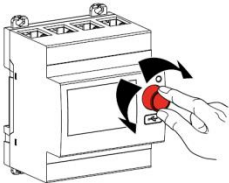

- Push: to confirm a choice, a parameter, etc...

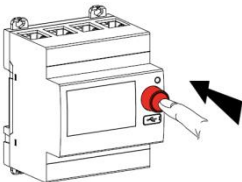



## 5. GENERAL CHARACTERISTICS (continued)

### Multi-Functions LED:

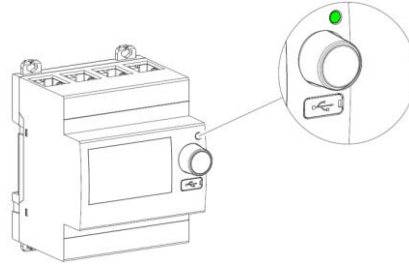
. Gives information about the operating state on the module



Possible states:

Led colour	State	Meaning
 red	Slow blinking	Error (e.g. addressing error)
	Fast blinking	No function
	Steady (without pressing the multifunction button)	System alarm detected (see Note*)
	Steady (pressing the multifunction button longer than 10 sec.)	Total reset [any firmware updates are preserved]
 green	Slow blinking	System process is running. Wait until the Led turns steady
	Fast blinking (pressing the multifunction button for 5 sec.)	put in "Stand-by" the EMS CX <sup>3</sup> module (no remote action and communication available)
	Steady	System OK, connection is running
 orange	Slow blinking	Creation of a link with "Link Functionality" procedure (see next §)
	Fast blinking	Device's firmware update in progress
	Steady	No function

### \* Note

. Possible system alarms detected by the Modbus/EMS Interface:

- loss of communication with an EMS module
- error in addressing procedure: possible mix between local and remote address (see § 6)
- duplicate function error: two EMS modules with the same function have the same address.

### . To turn off the system alarm:

- solve the problem according to the indication of the alarm
- push the Multifunction button on the Interface → the led become steady green

## 5. GENERAL CHARACTERISTICS *(continued)*

### Link Functionality:

. This function allows you to link two EMS CX<sup>3</sup> modules to create automatic actions that, once programmed, can run independently without a connection to a manager is needed.

The basic rule is the link between an event (circuit breaker that trip, a threshold exceeded, etc.) and an action accordingly (signalling, opening of a circuit by motorized control or contactor, etc.).

Possible associations are:

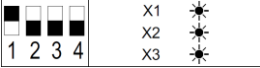
Event generator	Action module		
	Command: 4 149 32	State + Command: 4 149 31	State: 4 149 30
Measure: 4 149 19/20/23	✓	✓	✓ Only with the module configured (locally or remotely) as shown: 
State: 4 149 29/30	✓	✓	✗ Is sufficient to configure the module (locally or remotely) as "Slave"
State + Command: 4 149 31	✓	✓	✗ Is sufficient to configure the module (locally or remotely) as "Slave"

### Note:

- association can only be of type 1 to 1 (1 event and 1 action).
- modules already associated cannot be used for other associations.
- all the configuring procedure will be done with the Configuration Software (available online for free). *[For more details refer to the Installation Manual of EMS CX<sup>3</sup> Configuration software]*

### Modules compatible with "Link Functionality" feature: firmware versions and production date:

Cat n°	Firmware version	Production date indicated on the label sticked on the side of the module
4 149 19	ver. ≥ 2.0.1	date ≥ 18W29
4 149 20	ver. ≥ 2.0.1	date ≥ 18W49
4 149 23	ver. ≥ 2.0.1	date ≥ 18W49
4 149 29	ver. ≥ 2.0.1	date ≥ 18W49
4 149 30	ver. ≥ 2.0.2	date ≥ 18W32
4 149 31	ver. ≥ 2.0.6	date ≥ 18W45
4 149 32	ver. ≥ 3.0.2	date ≥ 18W39
4 149 36	ver. ≥ 2.0.4	date ≥ 18W38
4 149 37	ver. ≥ 2.0.4	date ≥ 18W43
4 149 40	ver. ≥ 3.0.8	date ≥ 18W34

### Insulation voltage:

. U<sub>i</sub> = 400 V

## 5. GENERAL CHARACTERISTICS *(continued)*

**Pollution degree:**

. 2 according to IEC/EN 60898-1.

**Overvoltage category:**

. III

**Dielectric strength:**

. 2500 V

**Plastic material:**

. Self-extinguishing polycarbonate.

**Ambient operating temperature:**

. Min. = -25°C. Max. = +70°C

**Ambient storage temperature:**

. Min. = -40°C. Max. = +70°C

**Protection Index:**

. Protection index of terminals against solid and liquid bodies (wired device): IP 20 (IEC/EN 60529).

. Protection index of the front face against solid and liquid bodies: IP 40 (IEC/EN 60529).

**Average weight per device:**

. 0,113 kg.

**Volume when packed:**

. 0,715 dm<sup>3</sup>.

**Consumption:**

. Values at 12 VDC

Configuration	W	mA
Backlight min.	0,175	14,6
Backlight 50%	0,322	26,8
Backlight 100%	0,438	36,5

**Mini-configurator menu tree**

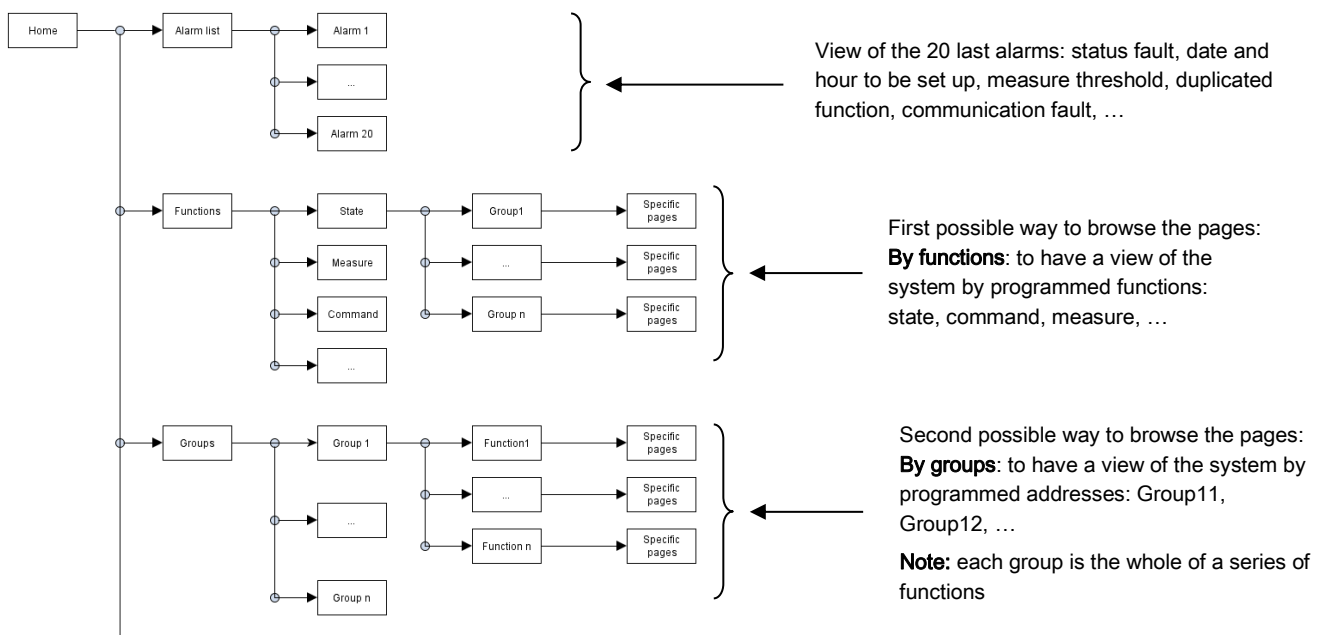

continue →

## 5. GENERAL CHARACTERISTICS (continued)

### Mini-configurator menu tree (continued):

→ follow

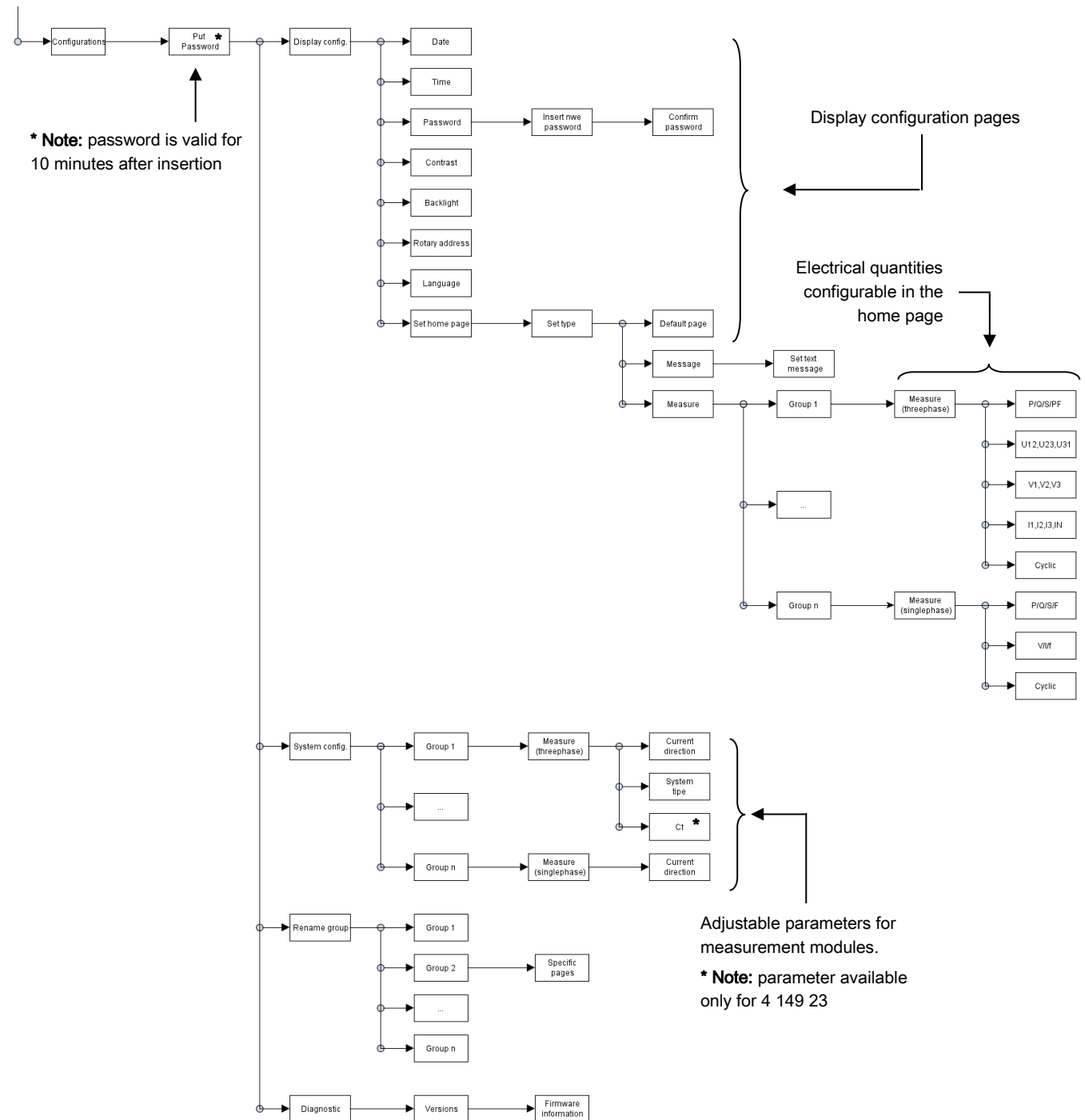

### Screen characteristics:

- . Type: LCD back lighted
- . Back light colour: white
- . Resolution: 240x128 pixel
- . Dimensions: 2"
- . Automatic backlight reduction, after 20 sec. of rotary button inactivity



## 6. SYSTEM ARCHITECTURES

The EMS CX<sup>3</sup> is a polyvalent system and, according to the needs of the customer, can be set up and/or used as “Stand-alone” or “Supervised” system. Based on this choice the configuration and addressing methods are different.

Four possible architectures are provided:

### 6.1 Stand-alone system

6.1.1 with local addressing (through the track wheel)

6.1.2 with remote addressing (through a computer)

### 6.2 Supervised (Computer Supervisory System)

6.2.1 with local addressing

6.2.2 with remote addressing

### 6.1 Stand-alone system

. **Stand-alone** = autonomous system. To be used by the end-user if it is not necessary to have a computer for the supervision outside the envelope. Everything can be managed on site.

#### 6.1.1 Stand-alone system with local addressing (through the track wheel)

Local addressing advantages:

- No configuration software needed to set-up the installation
- **It is not necessary to use a computer to manage settings** (configurations, test, ...) and to use the system (visualize and be alerted, ...). Everything can be done through the Mini configuration module (local display, cat. no 4 149 36/37). [see § “Menu tree”]
- No communication Interfaces or gateways are required.
- Installation can be done without the intervention of a System Integrator

#### Programming procedure:

. For EMS CX<sup>3</sup> modules which need some: mandatory through to lateral DIP-switch of each EMS CX<sup>3</sup> modules (see § “Module configuration” in the technical sheet of each device)

#### Addressing procedure:

. For all EMS CX<sup>3</sup> modules: mandatory through the track wheel located on the top upper face of each EMS CX<sup>3</sup> modules

. Marked from 0 to 9 in order to locally define the Modbus address of the EMS CX<sup>3</sup> modules

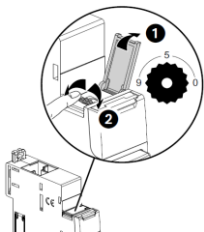

#### Consequences of the local addressing mode (through the track wheel):

- . Each device of the system must be addressed.
- . Addresses available: from 1 to 9
- . Address 0 not permitted
- . It is possible to assign to several devices the same address with the purpose of grouping different functions, **because they are related to the same electrical circuit**. For example, it is possible to assign the same address to a signalling auxiliary module (cat. no 4 149 29), a universal control module (cat. no 4 149 32), a measuring module, and so on. In this way on the EMS CX<sup>3</sup> mini configuration module (local display) the grouped function will be displayed as a unique “device” with all grouped functions. [Refer to the schemes hereunder]

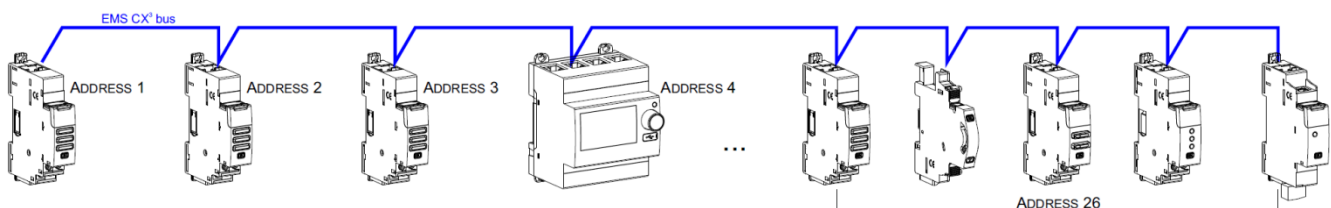

#### Note for the mini configuration module (local display)

- . It is possible to assign it the same address as another EMS CX<sup>3</sup> through the programming menu of the device
- . The mini configuration module can be placed everywhere in the EMS CX<sup>3</sup> bus



## 6. SYSTEM ARCHITECTURES

### 6.1 Stand-alone system *(continued)*

#### 6.1.2 Stand-alone system with remote addressing (through a computer)

Remote addressing advantages:

- Whole configuration (addresses and functions) can be set up through the EMS Configuration software
- Configuration software available for free
- **Automatic detection of the EMS CX<sup>3</sup> modules** installed in the system (characteristics, functions, configuration...)
- **Increased settings possibilities: load shedding function**
- Increased addressing: **up to 30 Modbus addresses in a system**

#### Programming procedure:

. For EMS CX<sup>3</sup> modules which need some: mandatory through to lateral DIP-switch of each EMS CX<sup>3</sup> modules *(see § "Module configuration" in the technical sheet of each device)*

#### Addressing procedure:

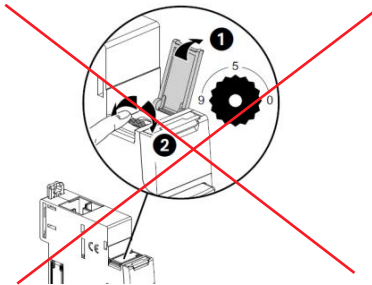

. It is not necessary to address the EMS CX<sup>3</sup> modules. The track wheel must be left in default position "0".

. All the addressing/configuring procedure will be done with the Configuration Software (available online for free)

. With remote addressing, the software does the automatic detection of modules installed in the system, but the supervision is not possible until the user assigns the remote address and all the characteristics to each module.

**Note: it is mandatory to connect the computer to the mini configuration module with an USB-micro USB cable.** *[ see § "Front USB port" ]*

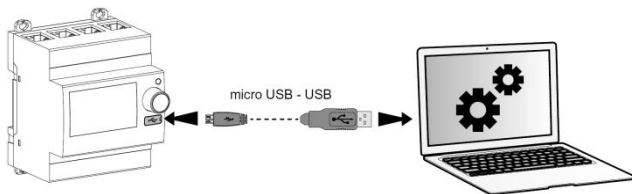

Read configuration from USB

Found:  
2 groups  
6 modules

Group modules in sets assigning the same address  
Press "Continue" to save address in modules and import structure.

Found modules			
Module ID	Model	Address	Error
FFFF.FFFF.FFFF.F0E5	4 149 36/37 - EMS display	247	-
FFFF.FFFF.FFFF.F0B8	4 149 30 - Generic input	1	-
FFFF.FFFF.FFFF.F0B9	4 149 32 - Generic command	2	-
FFFF.FFFF.FFFF.F0B8	4 149 26 - Pulse counter	3	-

Click on this icon on the table to light the LED on the module

legrand

## 6. SYSTEM ARCHITECTURES

### 6.1 Stand-alone system *(continued)*

#### 6.1.2 Stand-alone system with remote addressing (through a computer) *(continued)*

#### Consequences for the system architecture:

- for 1 mini configuration module (cat. no 4 149 36/67)
  - o up to **30 EMS CX<sup>3</sup> modules** (e.g. 30 devices grouped per functions with addresses from 1 to 30)

It is possible to assign to several devices the same address with the purpose of grouping different functions, **because they are related to the same electrical circuit**. For example, it is possible to assign the same address to a signalling auxiliary module (cat. no 4 149 29), a universal control module (cat. no 4 149 32), a measuring module, and so on. In this way on the EMS CX<sup>3</sup> display or in a supervision system the grouped function will be displayed as a unique “device” with all grouped functions. *[Refer to the schemes here under]*

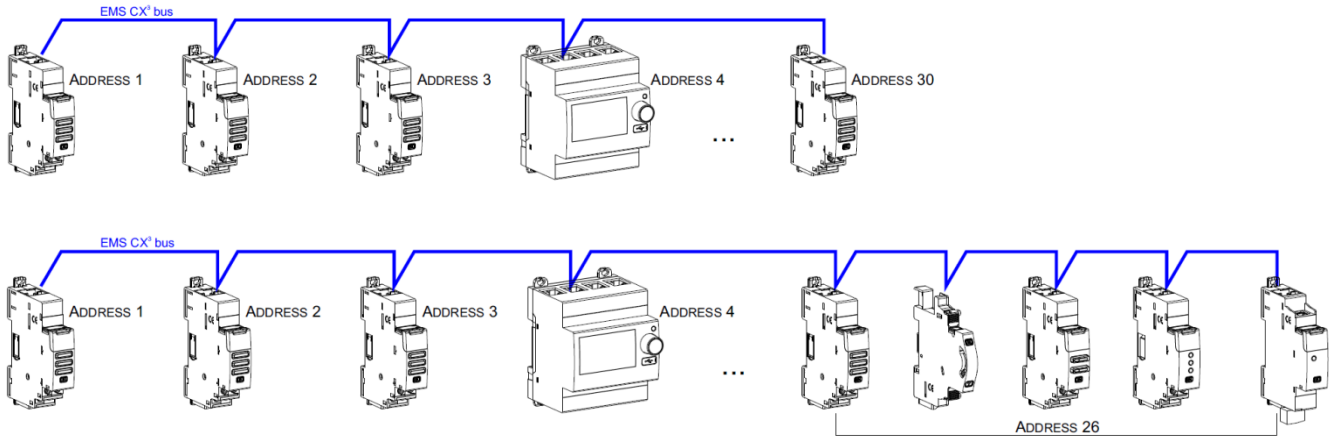

#### Note for the mini configuration module (local display)

- . It is possible to assign it the same address as another EMS CX<sup>3</sup>
- . The mini configuration module can be placed everywhere in the EMS CX<sup>3</sup> bus

### 6.2 Supervised system (Computer Supervisory System)

. **Supervised system** = System to be used through a Computer Supervisory System to remotely read data from the EMS CX<sup>3</sup> devices and/or do operations on these devices (e.g. commands of a motor driven or contactor ...).

#### 6.2.1 Supervised system-with local addressing (through the track wheel)

Local addressing advantages:

- No configuration software needed to set-up the installation
- Installation can be done without the intervention of a System Integrator

#### Programming procedure:

. For EMS CX<sup>3</sup> modules which need some: mandatory through to lateral DIP-switch of each EMS CX<sup>3</sup> modules *(see § "Module configuration" in the technical sheet of each device)*

#### Addressing procedure:

. For all EMS CX<sup>3</sup> modules: mandatory through the track wheel located on the top upper face of each EMS CX<sup>3</sup> modules

. Marked from 0 to 9 in order to locally define the Modbus address to EMS CX<sup>3</sup> modules

In this system the Modbus address of an EMS CX<sup>3</sup> module device or group of modules (several functions) is obtained considering the address of the interface Modbus/EMS CX<sup>3</sup> Interface as tenth and the address of a device or group of function as unit (e.g. Interface address 1 = 10 → address of module n°5 = Modbus address 15)

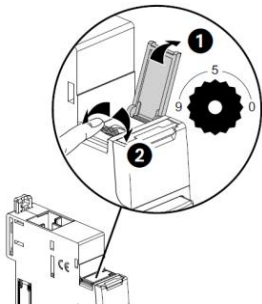

## 6. SYSTEM ARCHITECTURES *(continued)*

### 6.2 Supervised system (Computer Supervisory System) *(continued)*

#### 6.2.1 Supervised system-with local addressing (through the track wheel) *(continued)*

##### Consequences of the local addressing mode (through the track wheel):

- . Each device of the system must be addressed.
- . Addresses available: from 1 to 9
- . Address 0 not permitted

It is possible to assign to several devices the same address with the purpose of grouping different functions, **because they are related to the same electrical circuit**. For example, it is possible to assign the same address to a signalling auxiliary module (cat. no 4 149 29), a universal control module (cat. no 4 149 32), a measuring module, and so on. In this way on the EMS CX<sup>3</sup> display or in a supervision system the grouped function will be displayed as a unique “device” with all grouped functions. *[Refer to the scheme hereunder]*

**Note:** In this configuration the Modbus address of an EMS CX<sup>3</sup> module device or group of modules (several functions) is obtained considering the address of the interface Modbus/EMS CX<sup>3</sup> Interface as tenth and the address of a device or group of function as unit (e.g. Interface address 1 = 10 and device address = 5 → Modbus address = 15)

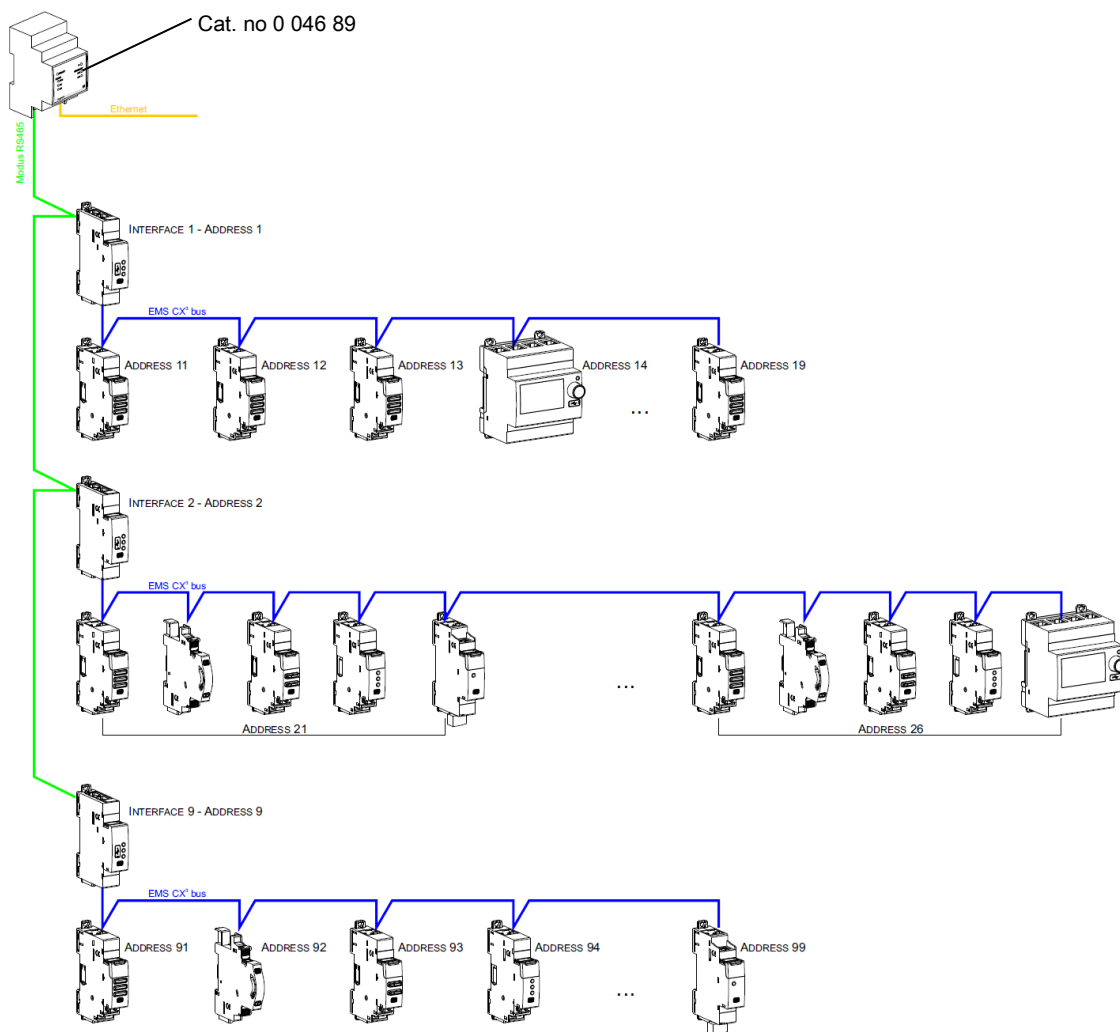

##### Consequences for the system architecture:

- for 1 IP/Modbus gateway (cat. no 0 046 89):
  - o up to **81 Modbus address**
  - o mandatory limit of max. **9 Modbus/EMS CX<sup>3</sup> interfaces** or max. **1000 m of Modbus cable** (cable Belden 9842, Belden 3106A or equivalent).
- for 1 Modbus/EMS CX<sup>3</sup> Interface (cat. no 4 149 40):
  - o up to **30 EMS CX<sup>3</sup> modules** (ex. 30 devices grouped per functions with addresses from 1 to 9)

**Note:** with local addressing, the Modbus/EMS CX<sup>3</sup> interface, does the automatic detection of modules (characteristics, functions, configuration...)

## 6. SYSTEM ARCHITECTURES *(continued)*

### 6.2 Supervised system (Computer Supervisory System) *(continued)*

#### 6.2.2 Supervised system-with remote addressing (through a computer)

Remote addressing advantages:

- Whole of configuration (addresses and functions) can be done a remotely through the EMS Configuration software
- Configuration software available for free
- **Automatic detection of the EMS CX<sup>3</sup> modules** installed in the system (characteristics, functions, configuration...)
- **Increased settings possibilities: load shedding function**
- Increased addressing: **up to 32 Modbus/EMS CX<sup>3</sup> interfaces**
- Increased addressing: **up to 247 Modbus addresses in a system**

#### Programming procedure:

. For EMS CX<sup>3</sup> modules which need some: mandatory through to lateral DIP-switch of each EMS CX<sup>3</sup> modules *(see § "Module configuration" in the technical sheet of each device)*

**Note:** via the configuration software it is possible to assign all the functions and characteristics of each EMS CX<sup>3</sup> module

#### Addressing procedure:

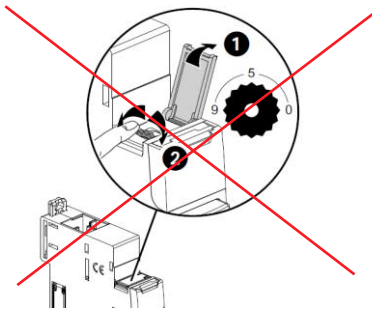

. It is not necessary to address the EMS CX<sup>3</sup> modules. The track wheel must be left in default position "0".

. All the addressing/configuring procedure will be done with the Configuration Software (available online for free)

. With remote addressing, the software does the automatic detection of modules installed in the system, but the supervision is not possible until the user assigns the remote address and all the characteristics to each module.

**Note: it is mandatory to connect the computer to the different Modbus/EMS CX<sup>3</sup> interface with an USB-micro USB cable (one interface at a time).** *[For more details, refer to the User Manual Document]*

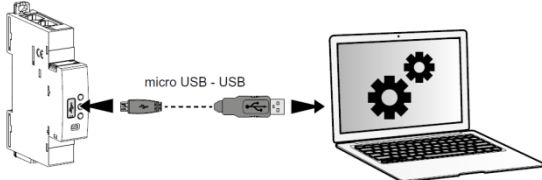

Read configuration from USB

**Found:**  
2 groups  
6 modules

Group modules in sets assigning the same address.  
Press "Continue" to save address in modules and import structure.

Module ID	Model	Address	Error
FFFF-FFFF-FFFF-FDF1	4 149 40 - Modbus/EMS interface	1	-
FFFF-FFFF-FFFF-FDB9	4 149 32 - Generic command	2	-
FFFF-FFFF-FFFF-FDB8	4 149 30 - Generic input	1	-
FFFF-FFFF-FFFF-FDB8	4 149 26 - Pulse counter	3	-

Click on this icon on the table to light the LED on the module

Basic    Refresh    Continue

**legrand**

## 6. SYSTEM ARCHITECTURES *(continued)*

### 6.2 Supervised system (Computer Supervisory System) *(continued)*

#### 6.2.2 Supervised system-with remote addressing (through a computer) *(continued)*

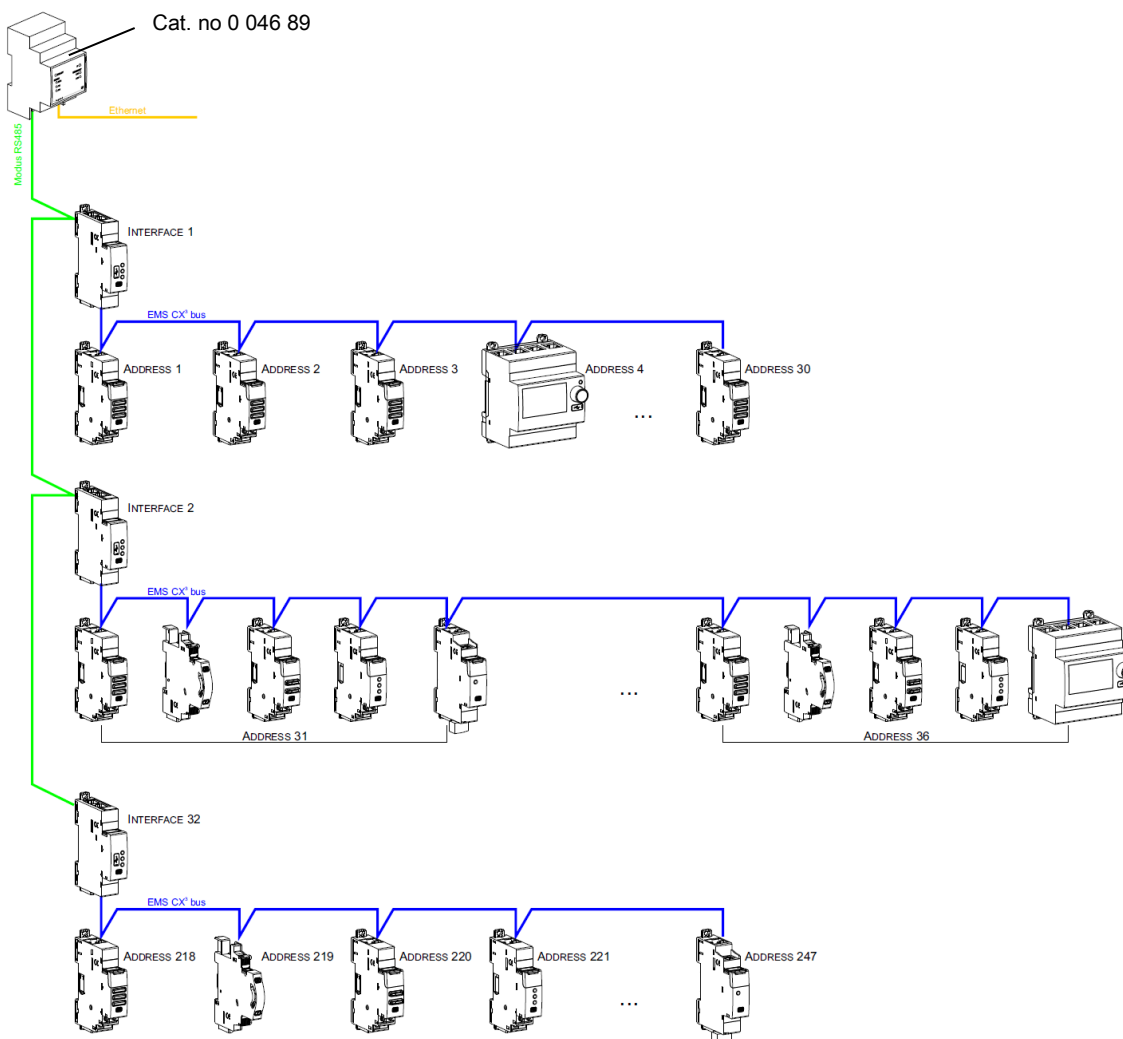

#### Consequences for the system architecture:

- for 1 IP/Modbus gateway (cat. no 0 046 89):
  - o up to **247 Modbus address**
  - o Because of Modbus: mandatory limit of max. **32 Modbus/EMS CX<sup>3</sup> interfaces** or max. **1000 m of Modbus cable** (cable Belden 9842, Belden 3106A or equivalent).
- for 1 Modbus/EMS CX<sup>3</sup> Interface (cat. no 4 149 40):
  - o up to **30 EMS CX<sup>3</sup> modules or grouped modules** (e.g. 30 devices grouped per functions with addresses from 1 to 30)

It is possible to assign to several devices the same address with the purpose of grouping different functions, **because they are related to the same electrical circuit**. For example, it is possible to assign the same address to a signalling auxiliary module (cat. no 4 149 29), a universal control module (cat. no 4 149 32), a measuring module, and so on. In this way on the EMS CX<sup>3</sup> display or in a supervision system the grouped function will be displayed as a unique “device” with all grouped functions. *[Refer to the scheme up here]*

## 7. COMPLIANCE AND APPROVALS

### Compliance to standards:

- . Compliance with Directive on electromagnetic compatibility (EMC) n° 2014/30/EU
- . Compliance with low voltage directive n° 2014/35/EU.
- . Electromagnetic Compatibility:  
IEC/EN 61131-2

### Environment respect - Compliance with EU directives:

- . Compliance with Directive 2011/65/EU as amended by Directive 2015/863 (RoHS 2) on the restriction of the use of certain hazardous substances in electrical and electronic equipment.
- . Compliance with REACH regulation (1907/2006): at the date of the publication of this document no element of the SVHC substance list (updated on 27/06/2018) is present in these products.
- . WEEE directive (2012/19/EU): the sale of this product is subject to a contribution to eco-organisations in each country responsible for managing end-of-life products in the field of application of the European Waste Electronic and Electrical Equipment Directive.

### Plastic materials:

- . Halogens-free plastic materials.
- . Marking of parts according to ISO 11469 and ISO 1043.

### Packaging:

- . Design and manufacture of packaging compliant to decree 98-638 of the 20/07/98 and also to directive 94/62/CE.

### Environmental profile:

- . PEP document available

### Installation software:

- . XL PRO<sup>3</sup>.